

NOTE: The knot drawings in this passport are from Chapter 1 of "Grant's Guide - Fishing Knots & Rigs" by Ern Grant, published by Herron Publications Pty Ltd, Fortitude Valley, Queensland, AU., Ph: (07) 3257 1711

<http://www.fishingcairns.com.au/page6-1.html>



NOTE: The knot drawings in this passport are from Chapter 1 of "Grant's Guide - Fishing Knots & Rigs" by Ern Grant, published by Herron Publications Pty Ltd, Fortitude Valley, Queensland, AU., Ph: (07) 3257 1711

<http://www.fishingcairns.com.au/page6-1.html>

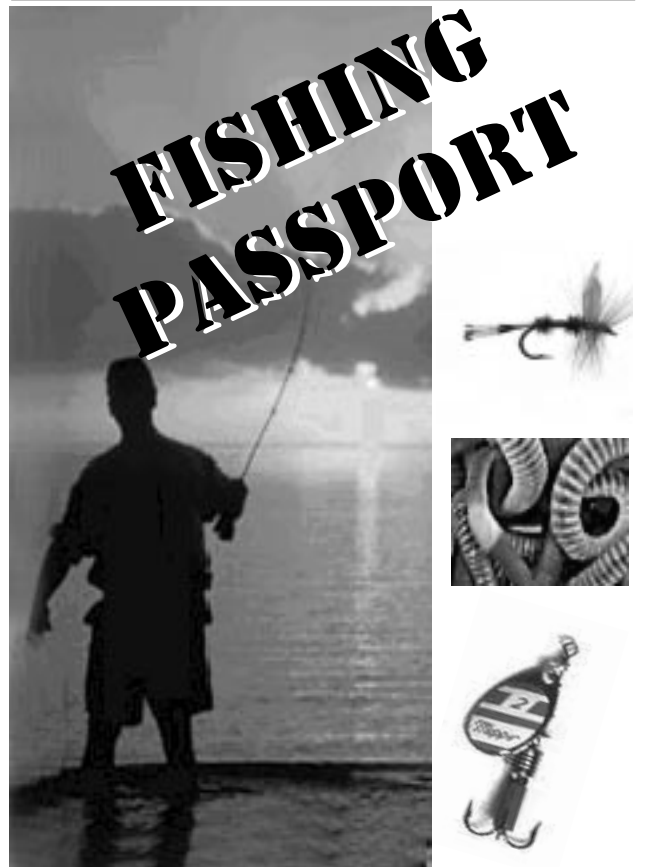

INJURIES & TREATMENT (1)

What is the proper treatment for:

cuts _____

scratches _____

puncture wounds (Skin punctured by a narrow sharp object)

hypothermia (Body temperature drops below 96° F. *Symptoms: Slow or irregular speech; shallow or very slow breathing; fatigue; confusion; slow pulse; weakness or drowsiness; shivering; cold pale skin.*)

What is the proper treatment for:

cuts _____

scratches _____

puncture wounds (Skin punctured by a narrow sharp object)

hypothermia (Body temperature drops below 96° F. *Symptoms: Slow or irregular speech; shallow or very slow breathing; fatigue; confusion; slow pulse; weakness or drowsiness; shivering; cold pale skin.*)

FISH CAUGHT (9)

Fish #1-Type caught: _____

Method used to catch fish: _____



Fish #2-Type caught: _____

Method used to catch fish: _____



How did you released one fish unharmed: _____

How did you cleaned and cooked one fish: _____

FISH CAUGHT (9)

Fish #1-Type caught: _____

Method used to catch fish: _____



Fish #2-Type caught: _____

Method used to catch fish: _____



How did you released one fish unharmed: _____

How did you cleaned and cooked one fish: _____

What does the Outdoor Code means to fisherman?

What about:

littering _____

trespassing _____

courteous behavior _____

obeying fishing regulations _____

dehydration (Body does not have enough fluids to function properly. Often caused by fluid loss (improper intake, vomiting, diarrhea or excessive urination).)

heat exhaustion (Body encounters excessively high temperatures that it can't manage. Body temperatures that are very high, but usually less than 104°F. *Symptoms: Signs of dehydration, weakness, headache, and nausea.*)

heat stroke (Severe injury from high body temperatures (usually greater than 104°F.) that cause damage to many organs. Two categories: **exertional**-exercising in excessively warm conditions; **classic**-remaining in warm environments too long. *Symptoms: Same as heat exhaustion plus confusion hallucinations, bizarre behavior, seizure, coma.*)

What does the Outdoor Code means to fisherman?

What about:

littering _____

trespassing _____

courteous behavior _____

obeying fishing regulations _____

dehydration (Body does not have enough fluids to function properly. Often caused by fluid loss (improper intake, vomiting, diarrhea or excessive urination).)

heat exhaustion (Body encounters excessively high temperatures that it can't manage. Body temperatures that are very high, but usually less than 104°F. *Symptoms: Signs of dehydration, weakness, headache, and nausea.*)

heat stroke (Severe injury from high body temperatures (usually greater than 104°F.) that cause damage to many organs. Two categories: **exertional**-exercising in excessively warm conditions; **classic**-remaining in warm environments too long. *Symptoms: Same as heat exhaustion plus confusion hallucinations, bizarre behavior, seizure, coma.*)

FISH HOOK REMOVAL (1)

If the hook is quite **shallow**, you can remove it by the string method. Thread a long string through the hook close to the skin. Wrap both ends around your wrist. While pushing down on the hook, *quickly* back out the hook.

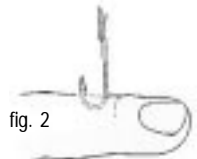

If the hook is **deep**, get *professional attention* if you are within a couple of hours of medical help.

If not, the hook may be pushed forwards and upwards until it re-exits the skin. The barb is then carefully clipped with a pair of wire cutters, and the remaining part of the hook is then backed out of the wound. Clean the wound and treat as a puncture wound.

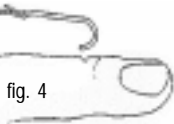

<http://www.kevinwakeman.com/fam/hookout.htm>

THE OUTDOOR CODE (8)

As an American, I will do my best to--

Be clean in my outdoor manners. I will treat the outdoors as a heritage. I will try to improve it for myself and others. I will keep my trash and garbage out of America's waters, fields, woods, and roadways.

Be careful with fire. I will prevent wildfire. I will build my fire in a safe place and be sure it is out before I leave.

Be considerate in the outdoors. I will treat public and private property with respect. I will remember that use of the outdoors is a right that I can lose by abuse.

Be conservation-minded. I will learn how to practice good conservation of soil, waters, forests, minerals, grasslands, wildlife, and energy. I will urge others to do the same.

FISH HOOK REMOVAL (1)

If the hook is quite **shallow**, you can remove it by the string method. Thread a long string through the hook close to the skin. Wrap both ends around your wrist. While pushing down on the hook, *quickly* back out the hook.

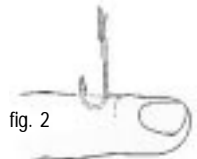

If the hook is **deep**, get *professional attention* if you are within a couple of hours of medical help.

If not, the hook may be pushed forwards and upwards until it re-exits the skin. The barb is then carefully clipped with a pair of wire cutters, and the remaining part of the hook is then backed out of the wound. Clean the wound and treat as a puncture wound.



<http://www.kevinwakeman.com/fam/hookout.htm>

THE OUTDOOR CODE

As an American, I will do my best to--

Be clean in my outdoor manners. I will treat the outdoors as a heritage. I will try to improve it for myself and others. I will keep my trash and garbage out of America's waters, fields, woods, and roadways.

Be careful with fire. I will prevent wildfire. I will build my fire in a safe place and be sure it is out before I leave.

Be considerate in the outdoors. I will treat public and private property with respect. I will remember that use of the outdoors is a right that I can lose by abuse.

Be conservation-minded. I will learn how to practice good conservation of soil, waters, forests, minerals, grasslands, wildlife, and energy. I will urge others to do the same.

PROPER CONDUCT (8)

Explain what good outdoor sportsmanlike behavior is.

How does it relate to fishermen? _____

SAFETY PRACTICES (1)

Name and explain five safety practices you should always follow while fishing:

1) _____

Why? _____

2) _____

Why? _____

3) _____

Why? _____

4) _____

Why? _____

5) _____

Why? _____

PROPER CONDUCT (8)

Explain what good outdoor sportsmanlike behavior is.

How does it relate to fishermen? _____

SAFETY PRACTICES (1)

Name and explain five safety practices you should always follow while fishing:

1) _____

Why? _____

2) _____

Why? _____

3) _____

Why? _____

4) _____

Why? _____

5) _____

Why? _____

RODS AND REELS (2)

List the main parts of a fishing rod.

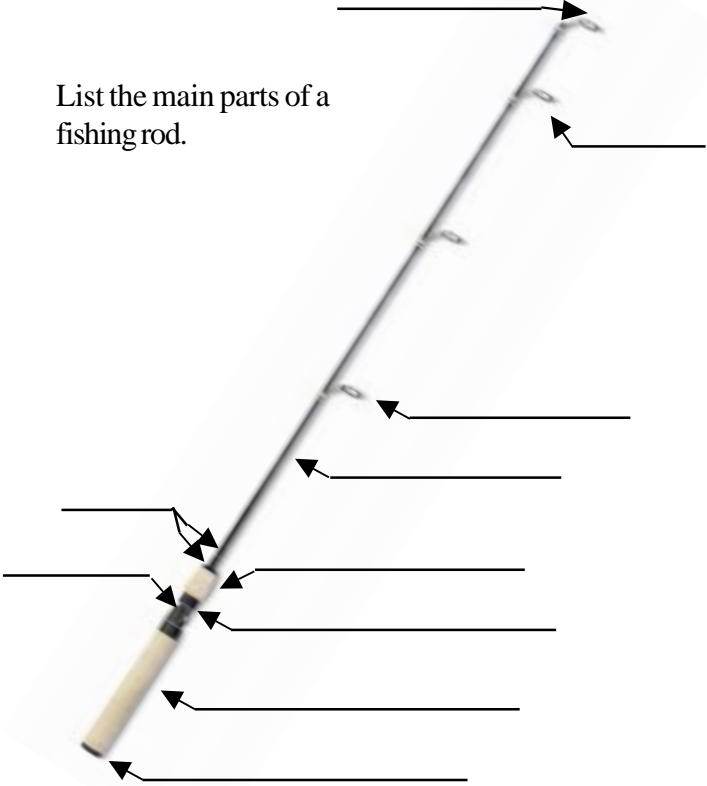

FISHING REGULATIONS (7)

List regulations affecting game fishing where you live.

What do you accomplish by following these regulations?



RODS AND REELS (2)

List the main parts of a fishing rod.

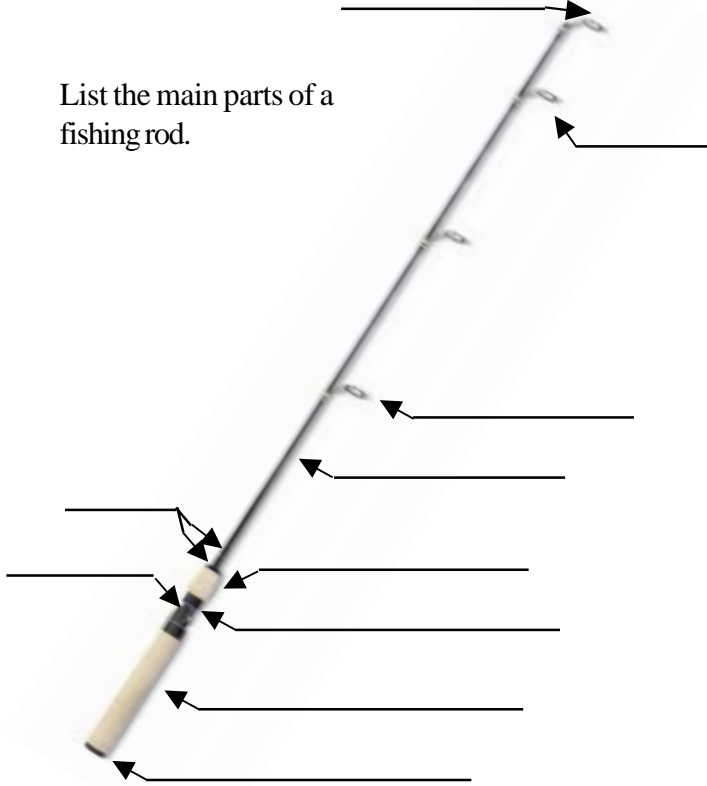

FISHING REGULATIONS (7)

List regulations affecting game fishing where you live.

What you accomplish by following these regulations?



BAIT FISH (5)

Why are bait fish not to be released?



LEAVE NO TRACE (6)

Explain the importance of practicing Leave No Trace.

How does it positively affects fishing resources?



BAIT FISH (5)

Why are bait fish not to be released?



LEAVE NO TRACE (6)

Explain the importance of practicing Leave No Trace.

How does it positively affects fishing resources?



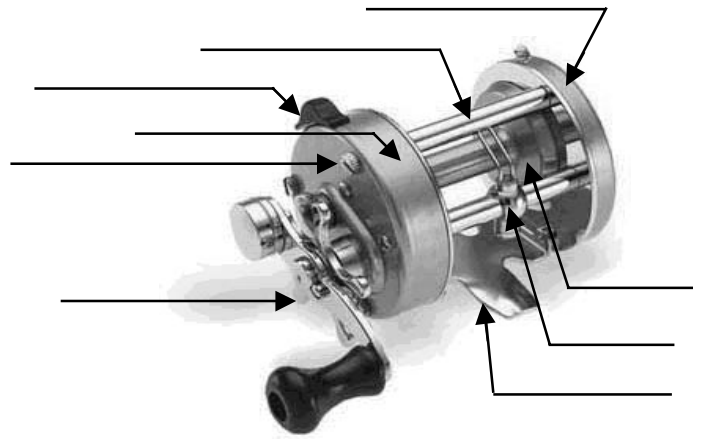

Name this type of fishing equipment:

Explain how to use this type of equipment (demonstrate how to use at least 2 of the 4 shown reels).

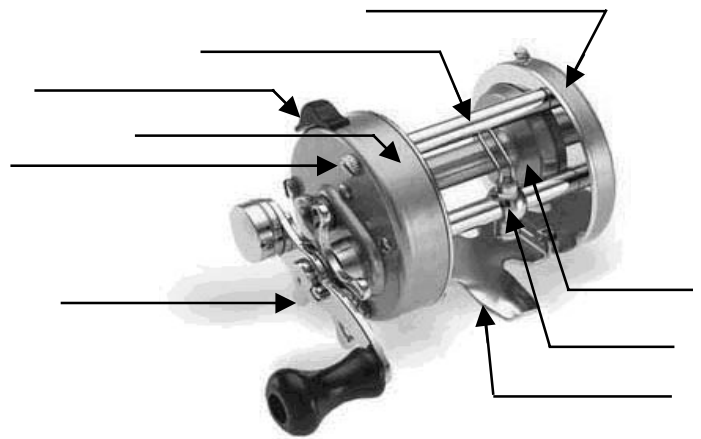

Name this type of fishing equipment:

Explain how to use this type of equipment (demonstrate how to use at least 2 of the 4 shown reels).





Name this type of fishing equipment:

Explain how to use this type of equipment (demonstrate how to use at least 2 of the 4 shown reels).

NATURAL BAITS (5)

	Name: Proper use:
--	----------------------

Name: Proper use:	
----------------------	---

	Name: Proper use:
--	----------------------

Name: Proper use:	
----------------------	---

	Name: Proper use:
--	----------------------

Name: Proper use:	
----------------------	---

	Name: Proper use:
--	----------------------





Name this type of fishing equipment:

Explain how to use this type of equipment (demonstrate how to use at least 2 of the 4 shown reels).

NATURAL BAITS (5)

	Name: Proper use:
--	----------------------

Name: Proper use:	
----------------------	---

	Name: Proper use:
--	----------------------

Name: Proper use:	
----------------------	---

	Name: Proper use:
--	----------------------

Name: Proper use:	
----------------------	---

	Name: Proper use:
--	----------------------

ARTIFICIAL LURES (5)



Name:
Proper use:

Name:
Proper use:



Name:
Proper use:



Name:
Proper use:

Name:
Proper use:



Name:
Proper use:



Name:
Proper use:

ARTIFICIAL LURES (5)



Name:
Proper use:

Name:
Proper use:



Name:
Proper use:



Name:
Proper use:

Name:
Proper use:



Name:
Proper use:



Name:
Proper use:



Name this type of fishing equipment:

Explain how to use this type of equipment
(demonstrate how to use at least 2 of the 4 shown reels).



Name this type of fishing equipment:

Explain how to use this type of equipment
(demonstrate how to use at least 2 of the 4 shown reels).

SURGEON'S LOOP (4)

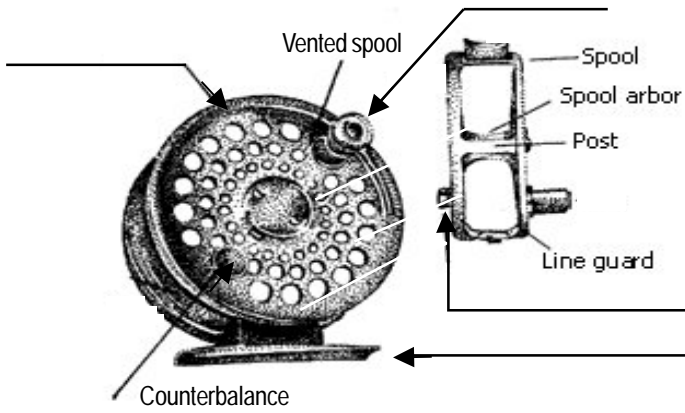

Name this type of fishing equipment:

Explain how to use this type of equipment (demonstrate how to use at least 2 of the 4 shown reels).

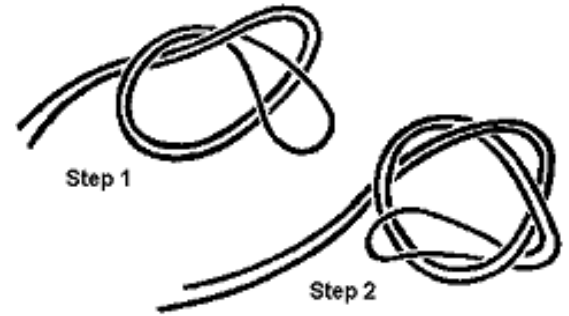

Take the end of the line and double it to form a loop of your needed size. Tie an overhand knot at the desired point, leaving the loop open. Bring the doubled line through the loop again. Hold the line and the end part together, and pull the loop to form a knot.



Proper uses: _____

SURGEON'S LOOP (4)

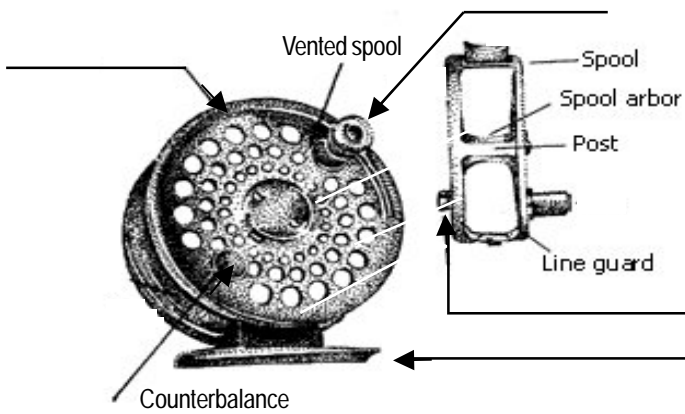

Name this type of fishing equipment:

Explain how to use this type of equipment (demonstrate how to use at least 2 of the 4 shown reels).

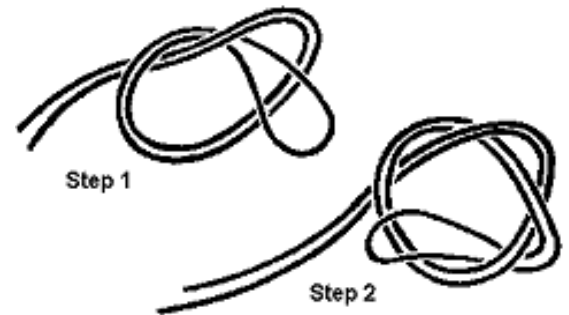

Take the end of the line and double it to form a loop of your needed size. Tie an overhand knot at the desired point, leaving the loop open. Bring the doubled line through the loop again. Hold the line and the end part together, and pull the loop to form a knot.



Proper uses: _____

BLOOD KNOT (4)

Lie the ends of lines against each other, overlapping about 6-inches. Take 5 turns around one line with the end of the other, and bring the end back where it's held between the two lines.

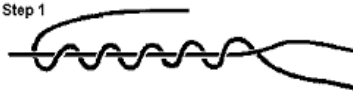

Repeat 5 turns around the other line, bringing the end back between the two lines.

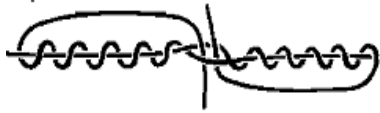

These two ends should then project in opposite directions. Work the knot up into loops, taking care that the two ends do not slip out of position. Draw the knot up tightly.



Proper uses: _____

BLOOD KNOT (4)

Lie the ends of lines against each other, overlapping about 6-inches. Take 5 turns around one line with the end of the other, and bring the end back where it's held between the two lines.

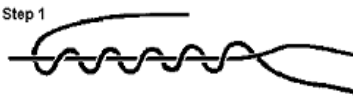

Repeat 5 turns around the other line, bringing the end back between the two lines.

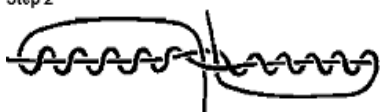

These two ends should then project in opposite directions. Work the knot up into loops, taking care that the two ends do not slip out of position. Draw the knot up tightly.



Proper uses: _____

CINCH KNOT (4)



Pass the line through the eye of the hook or swivel. Double back, making five turns around the line. Pass the end of the line through the first loop, above the eye. Draw the knot into shape and slide the coils down tight against the eye. This is the classic Cinch knot.

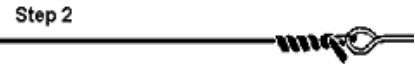

To tie the **Improved Cinch Knot**, continue by putting the line back through the large loop. Draw the knot into shape and slide the coils down tight against the eye.

Proper uses: _____

CINCH KNOT (4)



Pass the line through the eye of the hook or swivel. Double back, making five turns around the line. Pass the end of the line through the first loop, above the eye. Draw the knot into shape and slide the coils down tight against the eye. This is the classic Cinch knot.

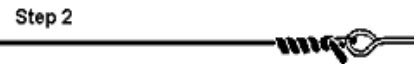

To tie the **Improved Cinch Knot**, continue by putting the line back through the large loop. Draw the knot into shape and slide the coils down tight against the eye.

Proper uses: _____

PALOMAR KNOT (4)

Simple but regarded as the strongest knot known. Double about 6" of line and pass the end through the eye. Loosely tie an overhand knot in the doubled line, letting the hook hang loose (avoid

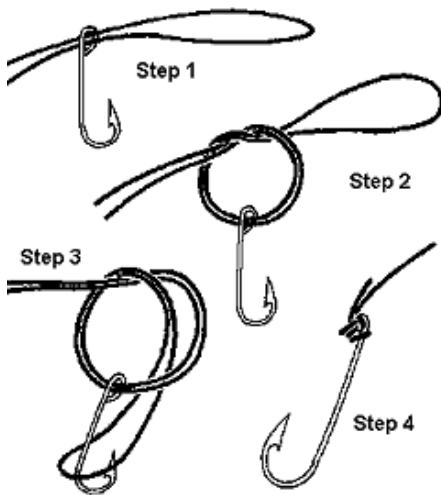

twisting the lines). Pull the end of the loop down and pass it completely over the hook. Pull both ends of the line to draw up the knot.

Proper uses: _____

TURLE KNOT (4)

A simple knot to tie, but also one of the weakest. Pass the line through the eye of the hook. Make a simple loop away from the hook.

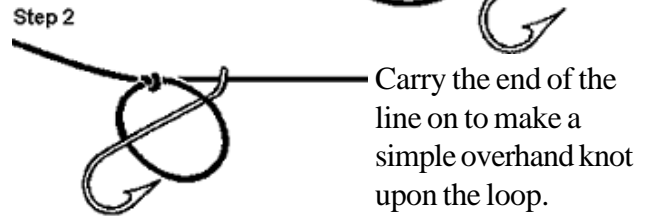

Pass the loop over the hook. Draw up to tighten knot into shape.



Proper uses: _____

PALOMAR KNOT (4)

Simple but regarded as the strongest knot known. Double about 6" of line and pass the end through the eye. Loosely tie an overhand knot in the doubled line, letting the hook hang loose (avoid

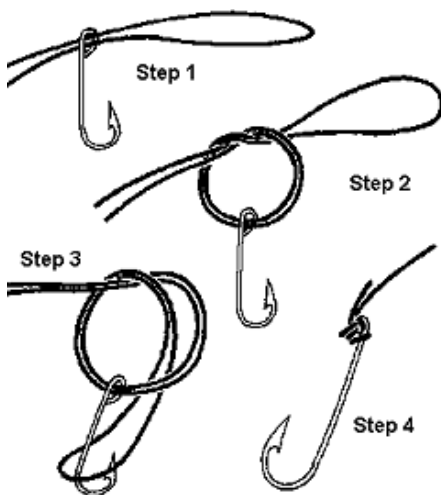

twisting the lines). Pull the end of the loop down and pass it completely over the hook. Pull both ends of the line to draw up the knot.

Proper uses: _____

TURLE KNOT (4)

A simple knot to tie, but also one of the weakest. Pass the line through the eye of the hook. Make a simple loop away from the hook.

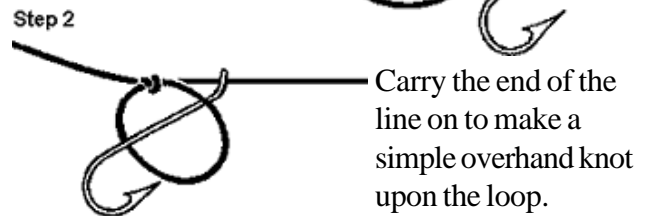

Pass the loop over the hook. Draw up to tighten knot into shape.



Proper uses: _____

