

Visit the "Scouting with Mr. R." web site at:
<http://www.relia.net/~thedane/scouting.html>

This passport belongs to:

Troop:
Campsite:



© 2004 Kerry Rasmussen, Mr. R.

**LEATHERWORK
PASSPORT**



Visit the "Scouting with Mr. R." web site at:
<http://www.relia.net/~thedane/scouting.html>

This passport belongs to:

Troop:
Campsite:



© 2004 Kerry Rasmussen, Mr. R.

**LEATHERWORK
PASSPORT**



SAFETY AND FIRST AID (1)

Identify and demonstrate to your counselor the safe use of leatherworking tools. _____



Explain and show correct procedures for handling leathercraft dyes, cements, and finished. _____

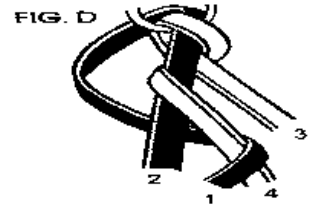
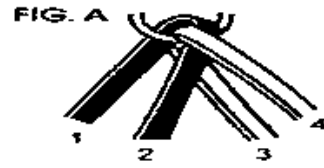

DIAMOND STITCH

SPIRAL STITCH

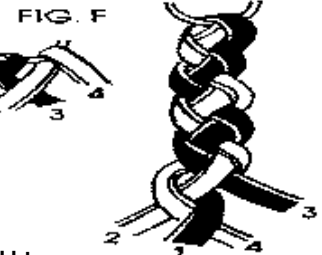
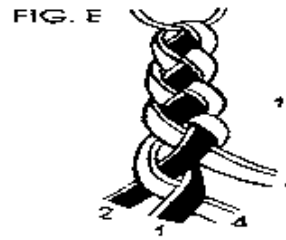

<http://www.cam.com/gimp/round.htm>

SAFETY AND FIRST AID (1)

Identify and demonstrate to your counselor the safe use of leatherworking tools. _____



Explain and show correct procedures for handling leathercraft dyes, cements, and finished. _____

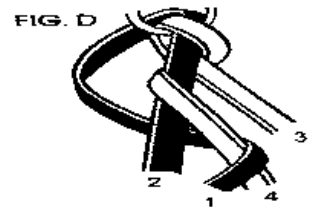
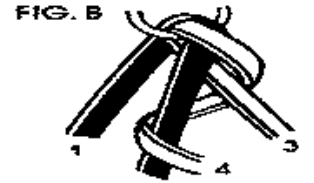

DIAMOND STITCH

SPIRAL STITCH

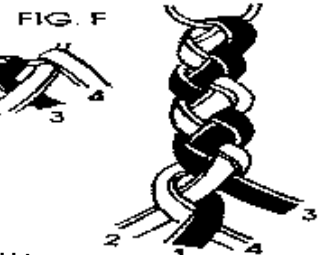
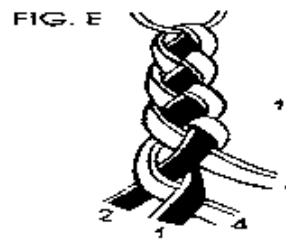

<http://www.cam.com/gimp/round.htm>

Round Braid

Materials: Choose 3 times the length of finished item.
(6 feet makes 2 feet of round braid, etc.)

Directions:

1. Choose 2 strands of lace. Hang snap hook on a nail, cup hook or suction cup hook with small end down. Draw both strands through the hook. Make certain all ends are even.
2. For diamond stitch, arrange strips as in Fig. A. Number strands 1, 2, 3, and 4 from left to right. You are ready to start braiding.
3. Place strand 4 under strands 3 and 2, then back over strand 2 (Fig. B). Pull strands tight (Fig.C).
4. Place strand 1 under strands 2 and 4, then back over 4 (Fig. D). Now pull strands tight! Untangle loose strand ends as you go and do not allow them to twist (Fig. E).
5. You have just completed the only two steps necessary to repeating steps (under 2 strands and back over 1) until desired length is braided.
6. The spiral stitch round braid is set up with 2 strands of alternating colors (Fig. F). Braid strands the same as for diamond stitch (under 2 strands and back over 1).
7. To fasten off, tie simple overhand knot to secure ends.

Round Braid

Materials: Choose 3 times the length of finished item.
(6 feet makes 2 feet of round braid, etc.)

Directions:

1. Choose 2 strands of lace. Hang snap hook on a nail, cup hook or suction cup hook with small end down. Draw both strands through the hook. Make certain all ends are even.
2. For diamond stitch, arrange strips as in Fig. A. Number strands 1, 2, 3, and 4 from left to right. You are ready to start braiding.
3. Place strand 4 under strands 3 and 2, then back over strand 2 (Fig. B). Pull strands tight (Fig.C).
4. Place strand 1 under strands 2 and 4, then back over 4 (Fig. D). Now pull strands tight! Untangle loose strand ends as you go and do not allow them to twist (Fig. E).
5. You have just completed the only two steps necessary to repeating steps (under 2 strands and back over 1) until desired length is braided.
6. The spiral stitch round braid is set up with 2 strands of alternating colors (Fig. F). Braid strands the same as for diamond stitch (under 2 strands and back over 1).
7. To fasten off, tie simple overhand knot to secure ends.

Know first aid for the following:

cuts (A physical slicing, tearing, or opening of the skin. *Symptoms: Skin may often open up being followed by bleeding. May or may not be very painful.*)

internal poisoning (Swallowing of toxic materials. *Symptoms: Sometimes a strong stomach pain or vomiting. The best indication of may be the presence of an open container of a toxic chemical.*)

skin irritation (If skin comes in contact with toxic materials or is exposed to toxic fumes for a long period of time. *Symptoms: Possible reddening or discoloration of the skin. Often followed by a rash and itching.*)

Know first aid for the following:

cuts (A physical slicing, tearing, or opening of the skin. *Symptoms: Skin may often open up being followed by bleeding. May or may not be very painful.*)

internal poisoning (Swallowing of toxic materials. *Symptoms: Sometimes a strong stomach pain or vomiting. The best indication of may be the presence of an open container of a toxic chemical.*)

skin irritation (If skin comes in contact with toxic materials or is exposed to toxic fumes for a long period of time. *Symptoms: Possible reddening or discoloration of the skin. Often followed by a rash and itching.*)

ABOUT LEATHER (2)

Where leather comes from? _____

What kinds of hides are used to make leather? _____

What are five types of leather? _____

- 1) _____
- 2) _____
- 3) _____
- 4) _____
- 5) _____

What are the best uses for each type of leather? _____

LEATHER TERMS: <http://www.iilg.org/lkb/articles/faq369.html>

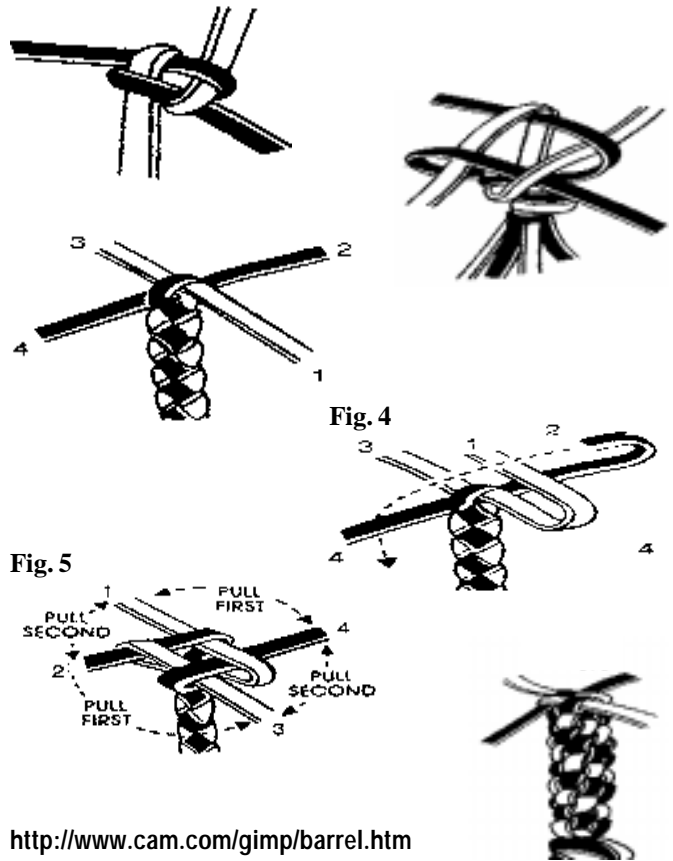

<http://www.cam.com/gimp/barrel.htm>

ABOUT LEATHER (2)

Where leather comes from? _____

What kinds of hides are used to make leather? _____

What are five types of leather? _____

- 1) _____
- 2) _____
- 3) _____
- 4) _____
- 5) _____

What are the best uses for each type of leather? _____

LEATHER TERMS: <http://www.iilg.org/lkb/articles/faq369.html>

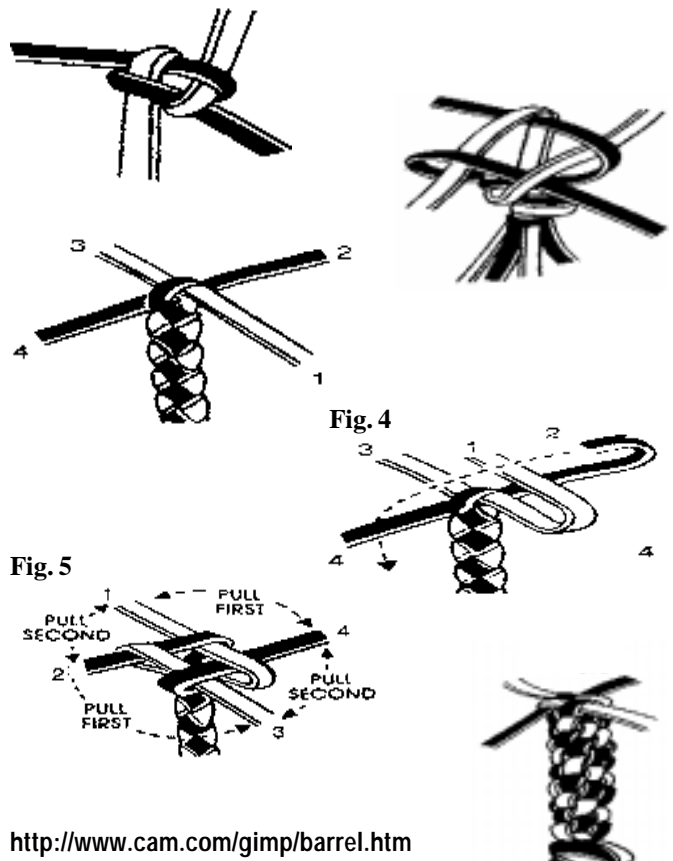

<http://www.cam.com/gimp/barrel.htm>

Barrel Stitch

Materials: Choose 2 strands of lace each 9 times the length of finished item (9 feet of gimp will make 12 inches of barrel stitch).

Directions:

1. Choose 2 strands of lace. Fold strands in half and into a snap hook.
2. Fold strand 1 to opposite side leaving a small loop. Fold strand over strand 1 leaving a small loop (Fig. 4). Hold both strands in place with fingers.
3. Fold strand 3 over strand 2 and hold.
4. Fold strand 4 over strand 3 and through loop left in strand 1.
5. Pull strands taut (Fig. 5). Take strands 1 and 4 in one hand, 2 and 3 in the other, and pull. Take 1 and 2 in one hand, and 3 and 4 in the other, and pull again. This completes the base of the barrel stitch. It is the same as the first stitch of the box stitch.
6. Fold strand 1 and 3 diagonally over previous stitch. Leave 2 small loops and hold. Fold strand 2 diagonally over strand 1, and through loop of 3. Fold strand 4 diagonally over strand 3, and through loop of 1. Pull strands tightly. You have just completed the only 2 steps necessary to make the barrel stitch. Continue until desired length is worked. The colors will form a spiral around the barrel as you work.
7. There are two ways to end the barrel stitch: 1) Tie the lace ends together in a simple overhand knot; 2) Leave the last stitch a little loose and bring the lace ends through the center of the last stitch, and pull the stitch tight. Clip the ends to 1 inch.
8. If desired, the barrel stitch may be used as a "slide" around a round braid or attached to a snap hook for a key chain fob.

Barrel Stitch

Materials: Choose 2 strands of lace each 9 times the length of finished item (9 feet of gimp will make 12 inches of barrel stitch).

Directions:

1. Choose 2 strands of lace. Fold strands in half and into a snap hook.
2. Fold strand 1 to opposite side leaving a small loop. Fold strand over strand 1 leaving a small loop (Fig. 4). Hold both strands in place with fingers.
3. Fold strand 3 over strand 2 and hold.
4. Fold strand 4 over strand 3 and through loop left in strand 1.
5. Pull strands taut (Fig. 5). Take strands 1 and 4 in one hand, 2 and 3 in the other, and pull. Take 1 and 2 in one hand, and 3 and 4 in the other, and pull again. This completes the base of the barrel stitch. It is the same as the first stitch of the box stitch.
6. Fold strand 1 and 3 diagonally over previous stitch. Leave 2 small loops and hold. Fold strand 2 diagonally over strand 1, and through loop of 3. Fold strand 4 diagonally over strand 3, and through loop of 1. Pull strands tightly. You have just completed the only 2 steps necessary to make the barrel stitch. Continue until desired length is worked. The colors will form a spiral around the barrel as you work.
7. There are two ways to end the barrel stitch: 1) Tie the lace ends together in a simple overhand knot; 2) Leave the last stitch a little loose and bring the lace ends through the center of the last stitch, and pull the stitch tight. Clip the ends to 1 inch.
8. If desired, the barrel stitch may be used as a "slide" around a round braid or attached to a snap hook for a key chain fob.

LEATHER ARTICLE (3)

Make one or more articles of leather that use at least five (5) of the following steps:

- Pattern layout and transfer
- Cutting leather
- Punching holes
- Carving or stamping surface designs.
- Applying dye or stain and finish to the project.
- Assembly by lacing or stitching
- Setting snaps and rivets
- Dressing edges



LEATHER ARTICLE (3)

Make one or more articles of leather that use at least five (5) of the following steps:

- Pattern layout and transfer
- Cutting leather
- Punching holes
- Carving or stamping surface designs.
- Applying dye or stain and finish to the project.
- Assembly by lacing or stitching
- Setting snaps and rivets
- Dressing edges



